

# Leo 3243 Pro

The Leo 3243 Pro is Tucsen's advanced solution for low-light, high-throughput imaging. Powered by next-gen stacked BSI sCMOS technology, it delivers outstanding 43 MP HDR performance at 100 fps via a high-speed 100 G CoF interface. With 3.2  $\mu\text{m}$  pixels and 21 Ke- full-well capacity, the Leo 3243 strikes an optimal balance between pixel size and well depth, making it ideal for modern scientific imaging systems.



## Key Features

## Benefits

Stacked BSI sCMOS	A systematic breakthrough in sensitivity, resolution and throughput has been achieved.
100G CoF Interface	Single interface bandwidth up to 100 Gbps, fast and easy integration.
100 fps@43 MP	10X higher than the throughput of typical BSI sCMOS cameras. <sup>[1]</sup>
31 mm Large Format	2.5X wider FOV than conventional 6.5 $\mu\text{m}$ sCMOS. <sup>[2]</sup>
3.2 $\mu\text{m}$ pixels	More adapter under 40X optical system of high precision sampling requirements.

## Typical Applications

- High Throughput Imaging
- Gene Sequencing
- Spatial Omics
- High Speed Industrial Inspection

## Noted Examples

[1]Leo 3243 Pro delivers 10X higher throughput by overcoming sensitivity, speed, and full well capacity trade-offs of traditional sCMOS.

Leo 3243 Pro **4300 Mpixel/s**  
100 fps@43 MP

Typical sCMOS **420 Mpixel/s**  
100 fps@4.2 MP

[2]Traditional sCMOS cameras usually have an 18.8 mm format, insufficient for high-throughput systems. The Leo 3243 Pro is better aligned with modern optical design trends.

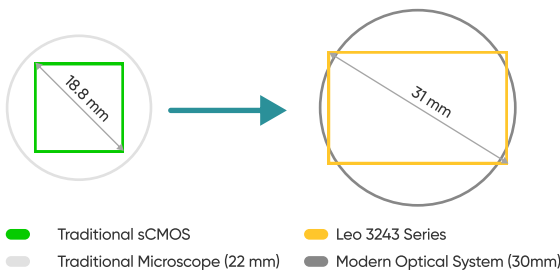

## Quantum Efficiency

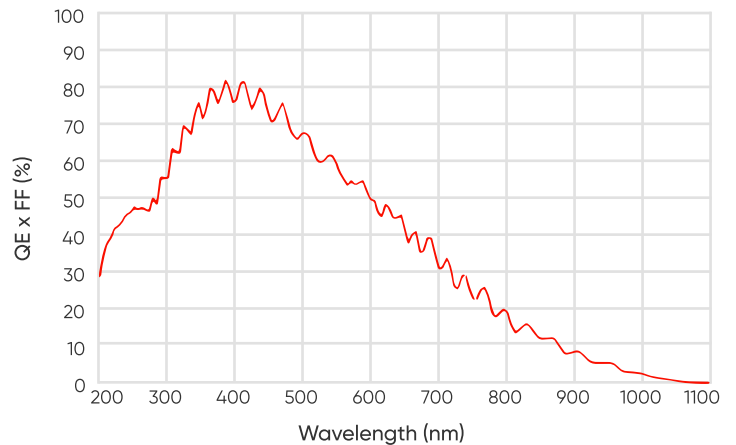

## Dimensions (Unit: mm)

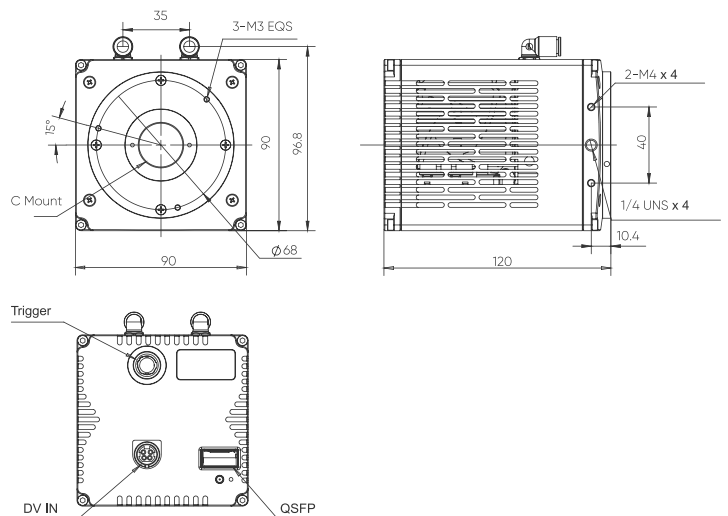

# Specifications

Model	Leo 3243 Pro			
Sensor Type	Stacked BSI sCMOS			
Sensor Model	Gpixel GSENSE3243BSI			
Peak QE	> 80%			
Chrome	Mono			
Array Diagonal	31 mm			
Effective Area	26.2 mm x 16.7 mm			
Resolution	8192 (H) x 5232 (V)			
Pixel Size	3.2 $\mu\text{m}$ x 3.2 $\mu\text{m}$			
Readout Mode	High Dynamic (HDR)	High Dynamic (Compressed)	High Speed (Low Gain)	High Speed (High Gain)
Bit Depth	16 bit	16 bit	14 bit	14 bit
Frame Rate	50 fps	100 fps	100 fps	100 fps
Readout Noise (median)	2.4 e <sup>-</sup>	2.5 e <sup>-</sup>	5.5 e <sup>-</sup>	1.9 e <sup>-</sup>
Full Well Capacity	15.5 Ke <sup>-</sup>	19 Ke <sup>-</sup>	21 Ke <sup>-</sup>	7.2 Ke <sup>-</sup>
Dynamic Range	Typical: 76 dB			
Shutter Mode	Rolling			
Exposure Time	HDR: 60 $\mu\text{s}$ -10 s			
Cooling Method	Air Cooling, Liquid Cooling			
Cooling Temp.	Air: 5°C, Liquid: -5°C (Regulated)			
Dark Current	< 0.5 e <sup>-</sup> /pixel/s@0°C Air Cooling			
Image Correction	DPC			
Binning	2 x 2, 4 x 4			
ROI	Support			
Timestamp Acc.	1 $\mu\text{s}$			
Trigger Mode	Hardware, Software			
Trigger Output	Exposure Start, Exposure End, Readout, Trigger Ready, First Row, Any Row, All Row			
Trigger Interface	Hirose-12-pin			
Data Interface	100G QSFP28			
Optical Interface	T / F / C Mount			
Power Supply	24 V / 6.6 A			
Power Cons.	98 W			
Dimensions	< 90 mm (H) x 90 mm (W) x 120 mm (L)			
Weight	< 1 kg			
Software	Sample Pro, LabVIEW, MATLAB, Micro-Manager 2.0			
SDK	C / C++ / C# / Python			
Operating System	Windows, Linux			
Environment	Working: Temp. 0°C~40°C, HUM 10%~85%; Storage: Temp. 0°C~60°C, HUM 0%~90%			

\*Specifications in this manual are subject to changes without prior notice.

