

Dhyana 9KTDI Pro

The Dhyana 9KTDI Pro camera is designed for speeding up light-limited acquisition with TDI technology and BSI-CMOS to offer the first scientific grade TDI device.

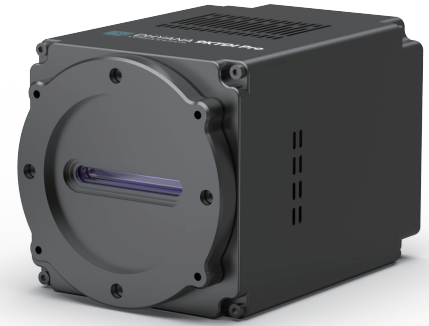

Key Features	Benefits
180-1100nm	Wide spectral response across UV / Visible / NIR.
82% Peak QE	High photon collection efficiency for lower illumination intensity.
256 Stages TDI	More TDI stages deliver higher SNR. ^[1]
600 kHz @ 9K	>54X faster than the back-illuminated TDI-CCD cameras. ^[2]
Air & Liquid Cooling	Maintains low dark noise, minimizes vibration, and aids thermal stability.

Typical Applications

- Wafer Inspection
- FPD Inspection
- Fluorescence Detection

Noted Examples

[1] More TDI stages deliver higher SNR.

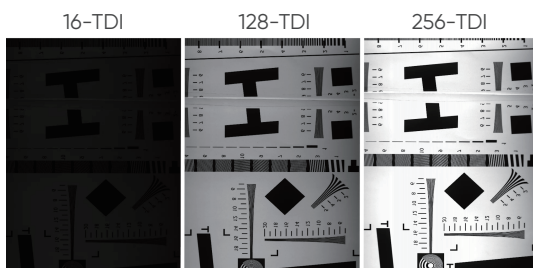

[2] > 54x faster than CCD technology.

	Mpixel / s
Dhyana 9KTDI Pro 9K @ 600 kHz	5400

BSI TDI-CCD 2K @ 50 kHz	100
----------------------------	------------

Quantum Efficiency

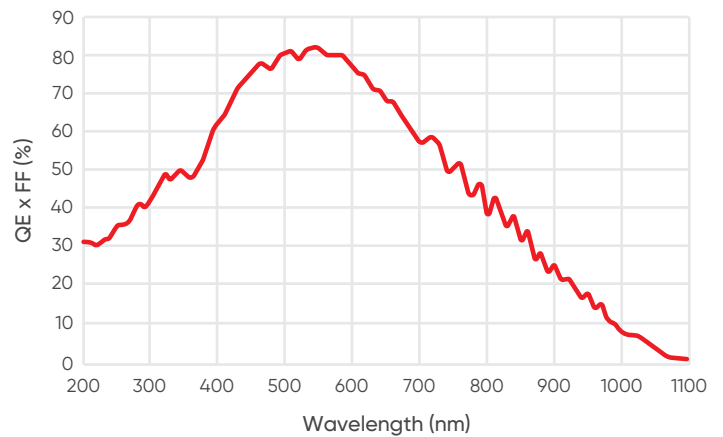

Dimensions (Unit: mm)

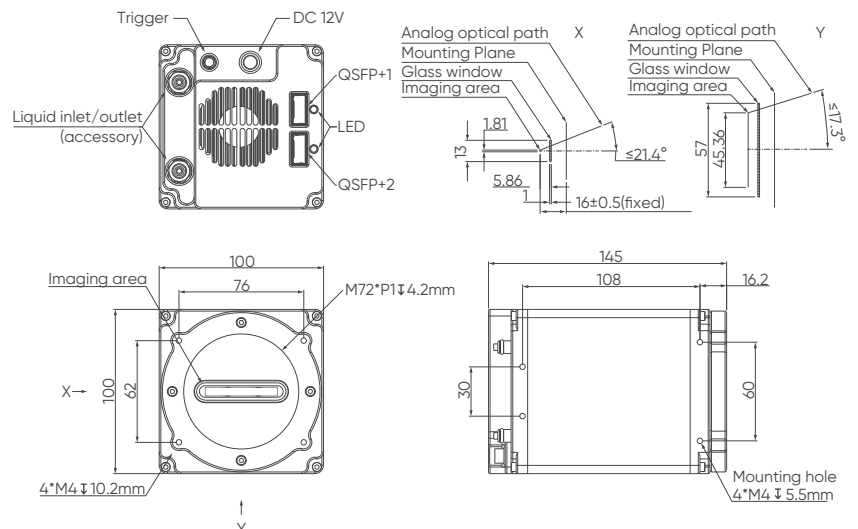

Technical Specifications

Model	Dhyana 9KTDI Pro
Sensor Type	BSI sCMOS TDI
Sensor Model	Gpixel GLT5009BSI
QE	82% @ 550 nm, 50% @ 350 nm, 38% @ 800 nm
Color / Mono	Mono
Array Diagonal	45.4 mm
Effective area	45.36 mm x 1.28 mm
Resolution	9072 (H) x 256 (V)
Pixel Size	5 μm x 5 μm
Operation Mode	TDI, Area
TDI Stage	4, 8, 12, 32, 64, 96, 128, 160, 192, 224, 240, 248, 252, 256
Scan Direction	Forward, Reverse, Trigger Control
CTE	≥ 0.99993
Data Bit Depth	12 bit, 10 bit, 8 bit
Full-Well Capacity	Typ. : 14 ke ⁻ @ 10 bit, 15.5 ke ⁻ @ 12 bit
Dynamic Range	Typ. : 68.7 dB @ 12 bit, 63.6 dB @ 10 bit
Max. Line Rate	300 kHz @ 12 bit, 600 kHz @ 10 bit, 600 kHz @ 8 bit
Readout Noise	7.2 e ⁻ @ 12 bit, 11.4 e ⁻ @ 10 bit
DSNU	Typ. : 1.5 e ⁻ @ 12 bit, 3.5 e ⁻ @ 10 bit
PRNU	Typ. : 0.30 %
Cooling Method	Air, Liquid, Cooling Speed 5 °C / min
Max. Cooling	35 °C below ambient
Binning	1 x 1, 2 x 1, 4 x 1, 8 x 1
ROI	Support
Trigger Mode	Trigger Input, Scan Direction Input
Output Trigger Signals	Strobe out
Trigger Interface	Hirose, HR10A-7R-4S
Timestamp Accuracy	8 ns
Gain	Analog Gain: x2 ~ x8, Step 0.5, Digital Gain: x0.5 ~ x10, Step 1
Data Interface	CoaxPress-Over-Fiber 2 x QSFP+
Optical Interface	M72 / User Customization
Power Supply	12 V / 8 A
Power Consumption	< 75 W
Dimensions	100 mm x 100 mm x 145 mm
Weight	1800 g
Software	Samplepro
SDK	C, C++, C#
Operating System	Windows, Linux
Operating Environment	Working: Temperature 0~40 °C, Humidity 0~85 % Storage: Temperature 0~60 °C, Humidity 0~90 %